

THIS DRAWING IS UNPUBLISHED. RELEASED FOR PUBLICATION
 © COPYRIGHT BY TYCO ELECTRONICS CORPORATION. ALL RIGHTS RESERVED.

LOC	DIST	REVISIONS					
		P	LTR	DESCRIPTION	DATE	DWN	APVD
H	-		R	ECR-07-002004	14-05-07	BSV	MK
			S	ECR-08-023872	16-10-08	AEG	KMA

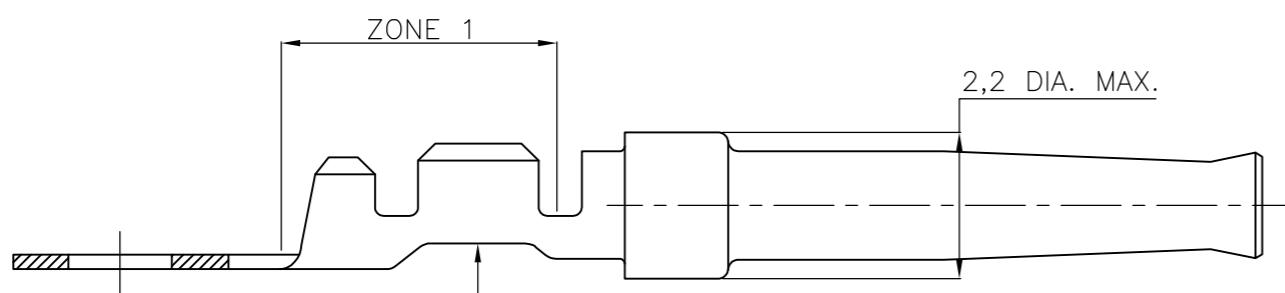

BLUE COLOR CODE (LOOSE-PIECE ONLY)

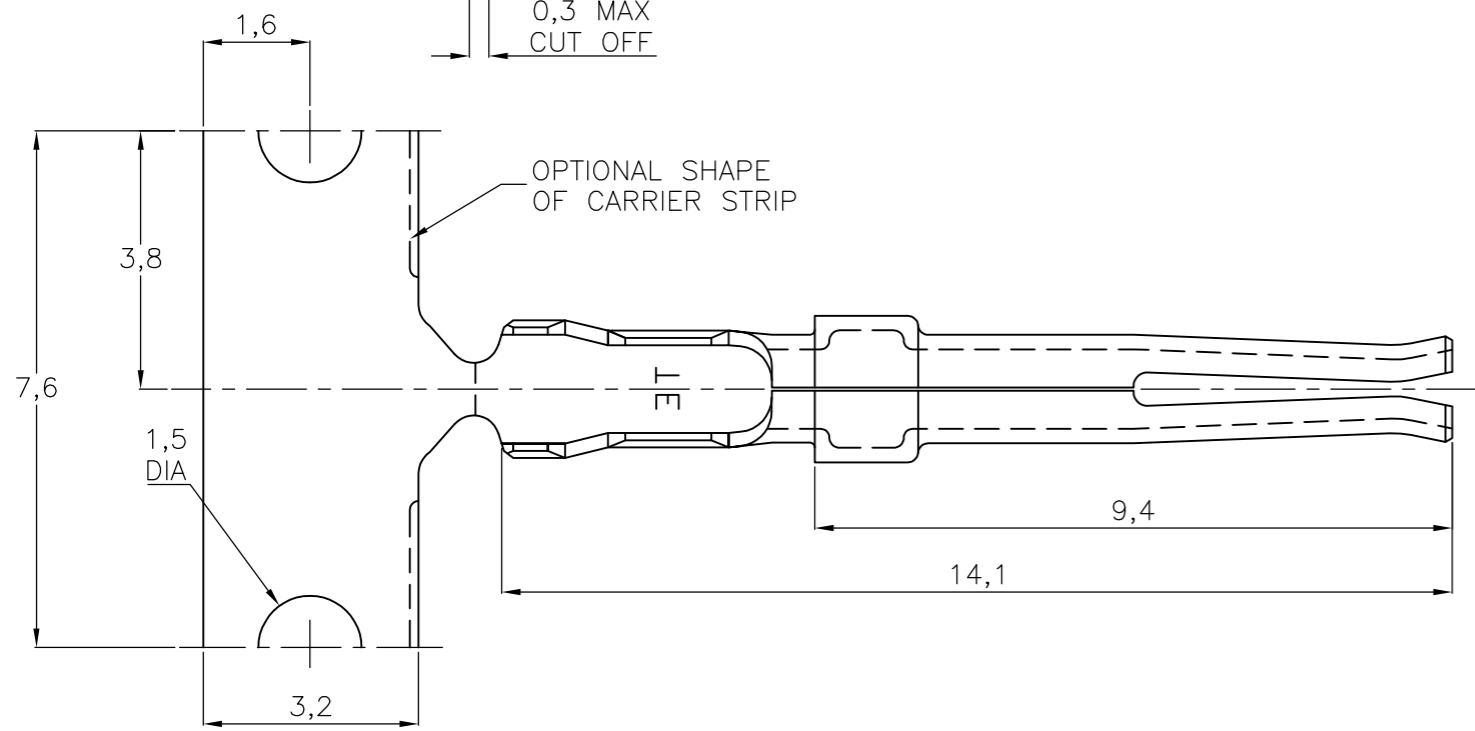
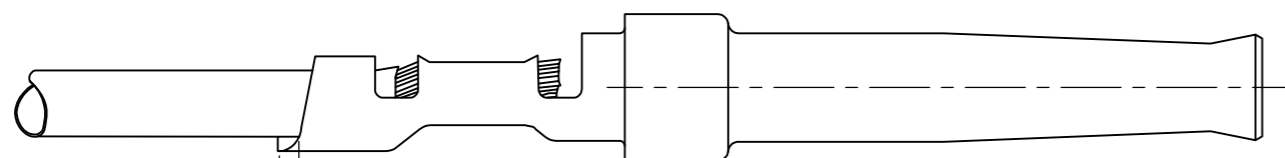
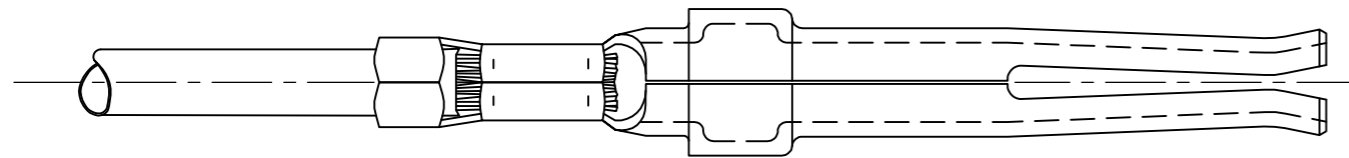
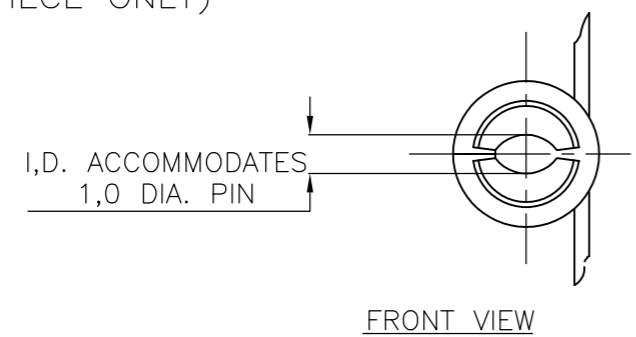

NOTES:

- 1 FOR MINI-APPLICATOR-12500 PCS REEL.
- 2 FOR REEL-FEED HAND TOOLING-500 PCS REEL.
- 3 FOR HAND TOOLING- LOOSE PIECE.
- 4. MATERIAL: PHOSPHORBRONZE.
- 5 FINISH:
 - Ni UNDERPLATING ALL OVER.
 - CONTACT AREA PLATING MEETS IEC-807-3 PERFORMANCE LEVEL 2.
 - CRIMP ZONE Sn PLATED.

WIRE RANGE: 28-24 AWG(0,08-0,22mm²)
 INSUL. RANGE: 0,76-1,02 DIA

5	166292-1	5-166052-1	166052-1
FINISH	LOOSE PIECE 3	PART NUMBER 2	PART NUMBER 1
DWN -		Tyco Electronics Corporation 's-HertogenBosch, Netherlands,	
CHK K.MALCZYK	09SEP08	NAME	
APVD I.DE BOER	09SEP08	SOCKET CONTACT, SIZE 20 DF.	
PRODUCT SPEC	108-40005	SIZE	CAGE CODE
APPLICATION SPEC	114-10000	DRAWING NO	RESTRICTED TO
WEIGHT -	A3 00779 C-166052		-
CUSTOMER DRAWING		SCALE NTS	SHEET 1 OF 1
			REV S

THIS DRAWING IS A CONTROLLED DOCUMENT.

DIMENSIONS:	TOLERANCES UNLESS OTHERWISE SPECIFIED:
mm	
	0 PLC ± -
	1 PLC ± 0,127
	2 PLC ± -
	3 PLC ± -
	4 PLC ± -
	ANGLES ± ± -
MATERIAL -	FINISH -